

AMAL

LIST
294B

PAGE 1

HINTS and TIPS for VERTICAL HORIZONTAL and INCLINED 1939 NEEDLE-JET CARBURETTORS

SINGLE
LEVER

DOUBLE
LEVER

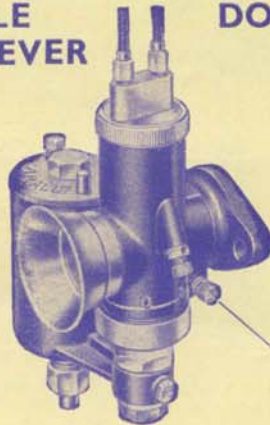

These instructions
also apply to earlier
models.

This screw is the
pilot air adjustment
and the one above it
is the adjustable
throttle stop.

AMAL LTD.

Holford Works, Perry Barr,
BIRMINGHAM, 20, England.

Phone: BIRchfields 4571.
(5 lines).

Telegrams: "AMALCARB, PHONE,
BIRMINGHAM."

INDEX.

1—This page.
2—Section of carburettor.
3—How it works.
4—Hints and tips.

5—How to trace faults.
6—Parts to tune up with.
7—How to tune up.
8—Pump carb. Service
and use of alcohol fuel.

SECTIONED ILLUSTRATION of NEEDLE JET CARBURETTER.

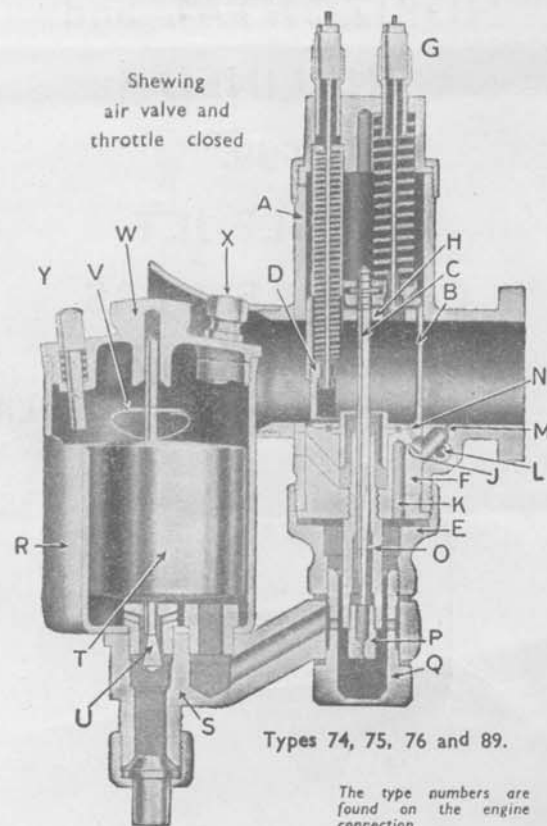

Fig. 2.

Your carburettor may be vertical, inclined or horizontal, but diagrammatically this view applies to all models, the variation being in the attachment to the engine and of the float chamber.

TWO DESIGNS.

(1). This view shows a section of the standard carburettor with the four external primary-air ports which are seen on the actual carburettor at the base of the mixing chamber, and where the air to the pilot system is separate and external.

(2). Another model carburettor is made where the primary-air is taken in through the main air intake, and this also feeds the pilot system (see illustration at foot of page 3).

These tuning instructions apply to all needle jet carburettors, 1929-1939.

HOW IT WORKS & PART NAMES

All models 1929-1939.

- | | |
|------------------------------|------------------------------------|
| A. Mixing Chamber. | N. Pilot By-pass. |
| B. Throttle Valve. | O. Needle Jet. |
| C. Jet Needle and Clip. | P. Main Jet. |
| D. Air Valve. | Q. Float Chamber Holding Bolt. |
| E. Mixing Chamber Union Nut. | R. Float Chamber. |
| F. Jet Block. | Throttle Stop (see pages 1 and 6). |
| G. Cable Adjusters. | T. Float. |
| H. Jet Block Barrel. | U. Float Needle. |
| J. Pilot Jet. | V. Float Needle Clip. |
| K. Passage to Pilot. | W. Float Chamber Cover. |
| L. Pilot Air Passage. | X. Float Chamber Lock Screw. |
| M. Pilot Outlet. | Y. Tickler. |

The carburetter proportions and atomises the right amount of petrol with the air that is sucked in by the engine because of the correct proportions of jet sizes and the main choke bore. The float chamber maintains a constant level of fuel at the jets and cuts off the supply when the engine stops.

The throttle control from the handlebar controls the volume of mixture and therefore the power, and at all positions of the throttle the mixture is automatically correct. The opening of the throttle brings first into action the mixture supply from the pilot jet system for idling, then as it progressively opens, via the pilot by-pass, the mixture is augmented from the main jet, the earlier stages of which action is controlled by the needle in the needle jet. The main jet does not spray directly into the mixing chamber, but discharges through the needle jet into the primary air chamber, and goes from there as a rich petrol-air mixture through the primary air choke into the main air choke. This primary air choke has a compensating action.

The carburetters usually have a separately-operated mixture control called an air valve for use when starting from cold, and until the engine is warm; this control partially blocks the passage of air through the main choke.

This design of carburetter offers perfectly simple and effective tuning facilities.

Fig. 3.
This section view does NOT apply if your carburetter has FOUR EXTERNAL primary air holes at the base of the mixing chamber. It is for carburetters with the primary air inlet in the main air intake.

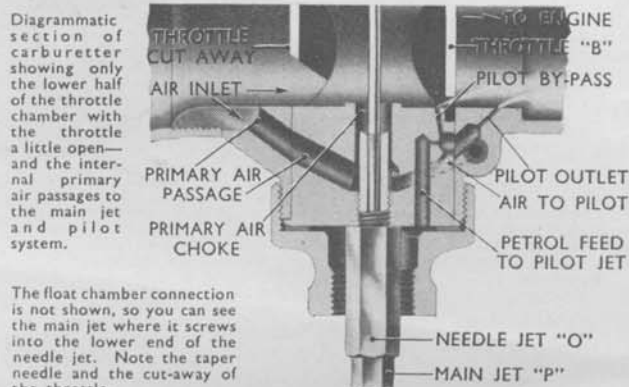

The float chamber connection is not shown, so you can see the main jet where it screws into the lower end of the needle jet. Note the taper needle and the cut-away of the throttle.

If the carburetter should flood whilst the engine is not running, the overflow from the main jet will run into the primary air passage and trickle out from there through a small hole seen at the side of the carburetter body.

HINTS AND TIPS.

STARTING from cold. Flood the carburetter by depressing the tickler Y sharply three or four times, and close the air valve ; set the ignition, say half retarded. Then shut the throttle and open it a little, viz., about one-eighth open, see diagram on page 7 position 2, then kick-start. If it is too much open starting will be difficult.

STARTING, engine hot. Do not flood the carburetter but close the air lever. Set the ignition and close the throttle, then open the throttle about one-eighth of its travel and kick-start. If the carburetter has been flooded and wont start because the mixture is too rich—open the throttle wide and give the engine several turns to clear the richness, then start again with the throttle one-eighth open, and air lever wide open. Generally speaking it is not advisable to flood at all when an engine is hot.

STARTING, general. By experiment, find out if and when it is necessary to flood, also note the best position for the air lever and the throttle for the easiest starting (some carburetters have the throttle stop fitted with a starting position on to which the throttle must be shut down).

STARTING, SINGLE LEVER CARBURETTERS. OPEN THE THROTTLE VERY SLIGHTLY FROM THE IDLING POSITION AND FLOOD THE CARBURETTER MORE OR LESS ACCORDING TO THE ENGINE BEING COLD OR HOT RESPECTIVELY.

CABLE CONTROLS. See that there is a minimum of backlash when the controls are set back and that any movement of the handlebar does not cause the throttle to open ; this is done by the adjusters on the top of the carburetter. See that the throttle shuts down freely.

PETROL FEED, verification. Detach petrol pipe union at the float chamber end ; turn on petrol tap momentarily and see that fuel gushes out. Avoid petrol pipes with vertical loops as they cause air locks. Flooding may be due to a worn or bent needle or a leaky float, but nearly all flooding with new machines is due to impurities (grit, fluff, etc.) in the tank—so clean out the float chamber periodically till the trouble ceases. If the trouble persists, the tank might be drained, swilled out, etc.

Note that if a carburetter, either vertical or horizontal, is flooding with the engine stopped, the overflow from the main jet will not run into the engine but out of the carburetter through the external primary air passages.

FIXING CARBURETTER AND AIR LEAKS. Erratic slow running is often caused by air leaks, so verify there are none at the point of attachment to the cylinder or inlet pipe—check by means of an oil can and eliminate by new washers and the equal tightening up of the flange nuts. Also in old machines look out for air leaks caused by a worn throttle or worn inlet valve guides.

BANGING IN EXHAUST may be caused by too weak a pilot mixture when the throttle is closed or nearly closed—also it may be caused by too rich a pilot mixture and an air leak in the exhaust system ; the reason in either case is that the mixture has not fired in the cylinder and has fired in the hot silencer. If the banging happens when the throttle is fairly wide open the trouble will be ignition—not carburation.

BAD PETROL CONSUMPTION of a new machine may be due to flooding, caused by impurities from the petrol tank lodging on the float needle seat and so prevent its valve from closing. If the machine has had several years use, flooding may be caused by a worn float needle valve.

Also bad petrol consumption will be apparent if the throttle needle jet "O" (see fig. 2) has worn ; it may be remedied or improved by lowering the needle in the throttle, but if it cannot be—then the only remedy is to get a new needle jet.

AIR FILTERS. These may affect the jet setting, so if one is fitted afterwards to the carburetter the main jet may have to be smaller. If a carburetter is set with an air filter and the engine is run without it, take care not to overheat the engine due to too weak a mixture, testing with the air valve (page 5, §4) will indicate if a larger main jet and higher needle position are required.

FAULTS, read page 5. The trouble may not be carburation ; if the trouble cannot be remedied by making mixture richer or weaker with the air-valve, and you know the petrol feed is good and the carburetter is not flooding, the trouble is elsewhere.

RE-ASSEMBLING after dismantling. Note particularly that the mixing chamber nut E (fig. 2, page 2), is tightened up tight on to the washer that holds the jet block F (fig. 2, page 2), otherwise petrol will leak up. When replacing the throttle see that the throttle needle goes into the centre hole in the choke block and once in, note the throttle works freely when the mixing chamber top ring is screwed down firmly.

Float chamber lid. To remove, first loosen screw X (fig. 2). To remove float, pinch the bow V (fig. 2), and pull ; when replacing, slip over needle and slide down till bow jumps into the needle groove. Care required to avoid bending needle.

HOW TO TRACE FAULTS.

There are only **TWO** possible faults in carburation, either **RICHNESS** of mixture or **WEAKNESS** of mixture, so in case of trouble decide which is the cause, by :—

1. Examining the petrol feed. } Verify jets and passages are clear.
 } Verify ample flow.
 } Verify there is no flooding.
2. Looking for air leaks. } At the connection to the engine.
 } Or due to leaky inlet valve stems.
3. Defective or worn parts } As a slack throttle—worn needle jet.
 } The mixing chamber union nut not
 } tightened up, or loose jets.
4. TESTING WITH THE AIR VALVE to see if by richening the mixture, the results are better or worse.

INDICATIONS OF :—

RICHNESS.
 Black smoke in exhaust.
 Petrol spraying out of carb.
 Four strokes, eight-stroking.
 Two strokes, four-stroking.
 Heavy, lumpy running.
 Heavy petrol consumption.
 ? If the jet block F is not tightened up by washer and nut E richness will be caused through leakage of petrol.
 ? Air-cleaner choked up.
 ? Needle jet worn large.
 Sparking plug sooty.

WEAKNESS.
 Spitting in carburettor.
 Erratic slow running.
 Overheating.
 Acceleration poor.
 Engine goes better if :—
 Throttle not wide open, or if
 Air valve is partially closed.
 ? Has air cleaner been removed.
 ? Jets partially choked up.
 REMOVING the silencer or running with a racing silencer requires a richer setting and large main jet.

NOTE :

Verify correctness of fuel feed, stop air leaks, check over ignition and valve operation and timing. **DECIDE BY TEST WHETHER RICHNESS OR WEAKNESS IS THE TROUBLE AND AT WHAT THROTTLE POSITION.** See throttle opening diagrams, page 7.

PROCEDURE.

If at a particular throttle opening you partially close the air valve and the engine goes better, weakness is indicated ; or on the other hand the running is worse, richness is indicated. THEN YOU PROCEED TO ADJUST THE APPROPRIATE PART AS INDICATED AT THE TOP OF PAGE 7 FOR THAT THROTTLE POSITION.

FAULT AT THROTTLE POSITIONS INDICATED ON PAGE 7

| TO CURE RICHNESS. | TO CURE WEAKNESS. |
|--|---|
| Fit smaller main jet. | 1st Fit larger main jet. |
| Screw out pilot air screw. | 2nd Screw pilot air screw in. |
| Fit a throttle with larger cutaway (§f, page 6). | 3rd Fit a throttle with smaller cutaway (§f, page 6). |
| Lower needle one or two grooves (§e, page 6). | 4th Raise needle one or two grooves (§e, page 6). |

NOTE. It is not correct to cure a rich mixture at half throttle by fitting a smaller main jet because the main jet may be correct for power at full throttle : the proper thing to do is to lower the needle.

CHANGING FROM STANDARD PETROLS TO SPECIAL FUELS, such as alcohol mixtures will, with the same setting in the carburettor, certainly cause weakness of mixture and possible damage from overheating. See note on page 8.

PARTS TO TUNE UP WITH.

(a) This fig. 4 is two diagrammatic sections of the carburettor to show :—

1. The throttle stop screw.
2. The pilot air screw.

NOTE.—The air for the pilot usually comes from outside but may also come from inside the carburettor.

(b) **THROTTLE STOP SCREW.** Set this screw to prop the throttle open sufficiently to keep the engine running when the twist grip is shut off.

(c) **PILOT AIR SCREW.** This screw regulates the strength of the mixture for "idling" and for the initial opening of the throttle. The screw controls the suction on the pilot petrol jet by metering the amount of air that mixes with the petrol.

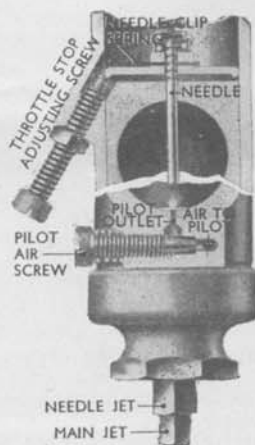

Fig. 4

(d) **MAIN JET.** The main jet controls the petrol supply when the throttle is more than three-quarters open, but at smaller throttle openings although the supply of fuel goes through the main jet, the amount is diminished by the metering effect of the needle in the needle jet.

Each jet is calibrated and numbered so that its exact discharge is known and two jets of the same number are alike. NEVER REAMER A JET OUT, GET ANOTHER OF THE RIGHT SIZE. The bigger the number the bigger the jet. Spare jets ARE SEALED.

To get at the main jet, undo the float chamber holding bolt Q (page 2). The jet is screwed into the needle jet so if the jet were tight, hold the needle jet also carefully with a spanner, whilst unscrewing it.

(e) **NEEDLE AND NEEDLE JET.** The needle is attached to the throttle and being taper—either allows more or less petrol to pass through the needle jet as the throttle is opened or closed throughout the range, except when idling or nearly full throttle. The needle jet is of a defined size and is only altered from standard when using alcohol fuels.

The taper needle position in relation to the throttle opening can be set according to the mixture required by fixing it to the throttle with the needle clip spring in a certain groove (see illustration above), thus either raising or lowering it. Raising the needle richens the mixture and lowering it weakens the mixture at throttle openings from $\frac{1}{4}$ to $\frac{3}{4}$ open (see illustration, page 7).

(f) **THROTTLE VALVE CUT-AWAY.** The atmospheric side of the throttle is cut away to influence the depression on the main fuel supply and thus gives a means of tuning between the pilot and needle jet range of throttle opening. The amount of cut-away is recorded by a number marked on the throttle, viz., 6/3 means throttle type 6 with No. 3 cut-away; larger cut-aways, say 4 and 5, give weaker mixtures and 2 and 1 richer mixtures.

(g) **AIR VALVE** is used only for starting and running when cold, and for experimenting with, otherwise run with it wide open.

(h) **TICKLER**, a small plunger spring loaded in the float chamber lid. When pressed down on the float, the needle valve is pushed off its seat and so "flooding" is achieved. Flooding temporarily enriches the mixture until the level of the petrol subsides to normal.



AMAL

PAGE 7

HOW TO TUNE UP.

PHASES OF AMAL NEEDLE JET CARBURETTER THROTTLE OPENINGS

Up to $\frac{1}{8}$ open | from $\frac{1}{8}$ to $\frac{1}{2}$ open | $\frac{1}{2}$ to $\frac{3}{4}$ open | $\frac{3}{4}$ to full open
PILOT JET | THROTTLE | NEEDLE- | MAIN JET
CUT-AWAY | POSITION | SIZE

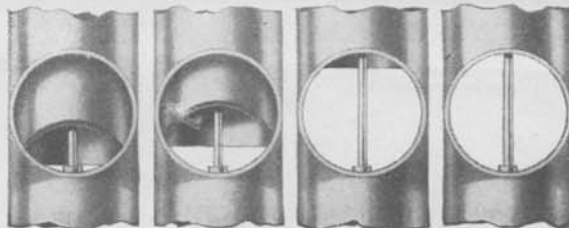

2ND & 5TH | 3RD | 4TH | 1ST

SEQUENCE OF TUNING

TUNE UP IN THE FOLLOWING ORDER ONLY, by so doing you will not upset good results obtained.

NOTE. The carburetter is automatic throughout the throttle range—the air valve should always be wide open except when used for starting or until the engine has warmed up. We assume normal petrols are used.

READ REMARKS ON PAGES 5 AND 6 for each tuning device and get the motor going preferably on a quiet road with a slight up gradient so that on test the engine is pulling.

1st. MAIN JET with throttle in position 1 (§d, page 6).
Test the engine for full throttle; if when at full throttle, the power seems better with the throttle less than wide open or with the air valve closed slightly the main jet is too small. If the engine runs "heavily" the main jet is too large. If testing for speed work note the jet size is rich enough to keep engine cool, and to verify this, examine the sparking plug by taking a fast run, declutching, and stopping engine quickly. If the plug body at the end has a bright black appearance the mixture is correct; if sooty, the mixture is rich; or if a dry grey colour, the mixture is too weak and a larger jet is necessary.

2nd. PILOT JET WITH THROTTLE IN POSITIONS 2 AND 5.
With engine idling too fast with the twist grip shut off and the throttle shut down on to the throttle stop screw, and ignition set for best slow running: (1) Loosen stop screw nut and screw down until engine runs slower and begins to falter, then screw the pilot air screw in or out to make engine run regularly and faster. (2) Now gently lower the throttle stop screw until the engine runs slower and just begins to falter, then lock the nut lightly and begin again to adjust the pilot air screw to get best slow running; if this 2nd adjustment makes engine run too fast, go over the job again a third time. Finally, lock up tight the throttle stop screw nut without disturbing the screw's position.

3rd. THROTTLE CUTAWAY with throttle in position 3 (§f, page 6).
If, as you take off from the idling position, there is objectionable spitting from the carburetter, slightly richen the pilot mixture by screwing the air screw in about half a turn, but if this is not effective, screw it back again and fit a throttle with a smaller cutaway. If the engine jerks under load at this throttle position and there is no spitting, either the throttle needle is much too high or a larger throttle cutaway is required to cure richness.

4th. NEEDLE with throttle in position 4 (§e, page 6).
The needle controls a wide range of throttle opening and also the acceleration. Try the needle in as low a position as possible, viz., with the clip in a groove as near the end as possible; if acceleration is poor and with air valve partially closed the results are better, raise the needle by two grooves; if very much better try lowering needle by one groove and leave it where it is best.

Note, if mixture is still too rich with clip in groove No. 1 nearest the end—the Needle jet probably wants replacement because of wear. The needle itself never wears out.

5th. FINALLY go over the idling again for final touches.

SERVICE ARRANGEMENTS.

There are many AMAL Service Stockists in Gt. Britain and in other countries where motor-cycling is popular: you are strongly recommended to purchase spares from them and to consult them about your requirements.

GENUINE AMAL SPARES are sold by our stockists, and you will get them either **packeted** or **sealed** under the name **AMAL**. Our spares are made in our factory under the same conditions of gauging and inspection as the parts used in the manufacture of each carburetter.

JETS. All spare jets are sealed with a soft wire through the orifice so that the orifice cannot be tampered with. All jets for the carburetters here described are type No. 4/042 with a list price of 5d. each. They are made in sizes 30, 35, 40 c.c., etc., with increments of 5 c.c. up to 100 c.c., and from 100, 110, 120 c.c. to 500 c.c. by increments of 10 c.c.

The meaning of c.c. is that the jets will pass the marked number of cubic centimetres of petrol under conditions of test on the Amal jet calibrating machine—which machines are adopted as a national standard. Each jet you get has been individually tested before marking.

Spares generally. All are listed at fixed prices.

SERVICE STOCKISTS HAVE OUR LISTS OF RECOMMENDED SETTINGS FOR ALL STANDARD MOTOR-CYCLE CARBURETTERS.

Use of Special Alcohol Fuels.

When using alcohol fuels it is essential that a needle jet stamped .113 should be fitted together with jet sizes increased as follows :—

Approximately 60% for P.M.S. 2 fuel.
" 80% for R.D.1 fuel.
" 150% for JAP racing fuel.
" 200% for Pratt's racing spirit and Ethyl.

Example : If your carburetter is set for straight petrols and you intend to use, say P.M.S.2 fuel, you must alter the needle jet, see page 2, part O, for the larger size marked .113, and increase the jet size by 60%: if your jet is say 200 c.c. it must be increased to 320 c.c., because 60% on 200 c.c. is 120, and $200 + 120 = 320$ c.c.

IF YOU ARE PURCHASING A CARBURETTER

do not assume that because the carburetter fits on to the pipe, that it is the right one for your machine : consult our list 340C for the correct size choke bore.

TUNING THE ACCELERATION PUMP CARBURETTER.

This carburetter may have the needle one notch lower in the throttle than a carburetter without the pump. However, tuning should be carried out on the pump type carburetter in exactly the same way as for the non-pump type, but the main jet should be approximately 15% larger in the pump carburetter than in a carburetter without pump, for example, main jet 150 without pump would mean main jet 170 with pump.

Important Note. To start from cold, turn on petrol tap and first open the throttle wide twice and then close to the best starting position. This primes the carburetter better than flooding. Do not open and shut the throttle unnecessarily when the machine is not running, otherwise you might over-prime the carburetter. If you do over-prime open the throttle wide and give a couple of kicks, then close down to the best starting position.

The pump action of the carburetter when the engine is running does NOT glut the engine with petrol.

If you remove the pump piston see that you replace it the correct way up that is, with the 4 holes at the top.